

Dimensions

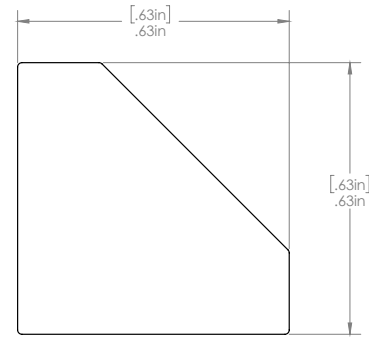

Optics

Flat Milky

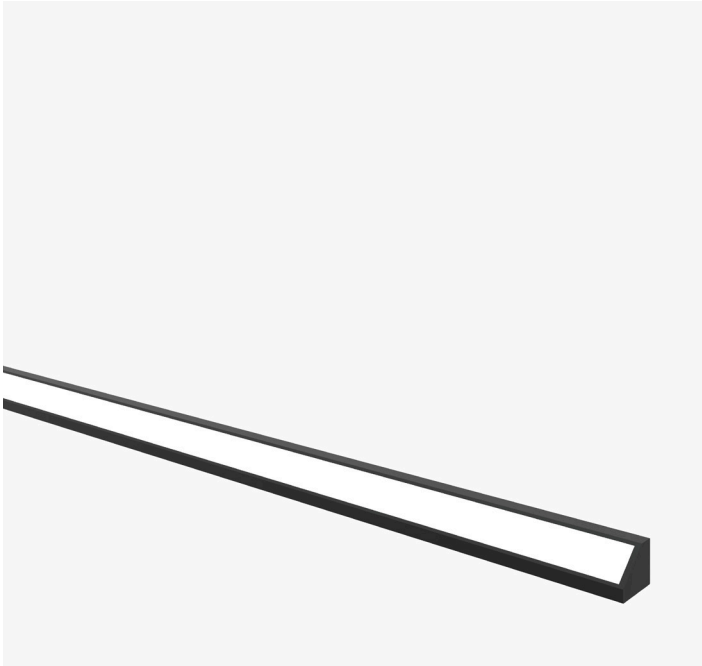
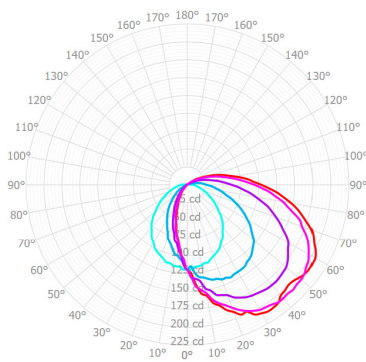

Spec Lock

- LED specially binned through forward voltage within a 3-step MacAdam ellipse for increased CCT fidelity and smooth lower end dimming.
- Mechanically fastened Rigid PCB set within an extruded aluminum channel for simple installation and total serviceability.
- Pressure fit metal pin connection for solderless in-field connection between LED boards for a seamless appearance.
- Flexible power feed injections maintain LED pitch consistency for a plethora of mounting options.
- Never a shadow, hotspot nor break in light no matter the output and run length.
- No double-sided adhesion (tape) or soldering during installation.



FlexDuo Corner

SCOUT

Part # Builder

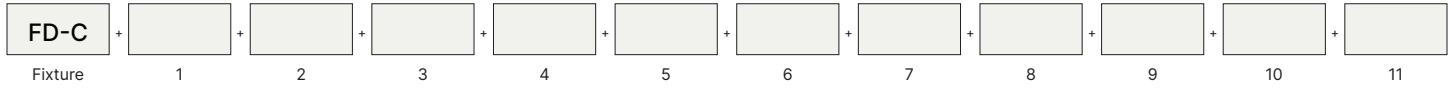

| Fixture | 1 : Lens | 2 : Intensity ¹ | 3 : Color Temp |
|-----------------------------|--|---|--|
| FD-C : Zip Corner | FM : Flat Milky | L : Low (388lm/2.8w per ft) H : High (1092lm/8.3w per ft) | 27 : 2700K 30 : 3000K 35 : 3500K |
| 4 : Finish ² | 5 : Feed ³ | 6 : Control | 7 : Mounting |
| N : None | EF : End Feed RF : Rear Feed SF1 : Side Feed 1 | 0 : None 1 : 0-10 -1% Dimming 2 : 0-10 - 0.1% Dimming 3 : DMX/ DALI 4 : POE 5 :ELV / MLV / Phase 6 : 0-10 Tuneable White 7 : 0-10 Warm Dim 8 : Lutron Hi-Lume 1% Ecosystem W/ SO-FTB 9 : Lutron Hi Lume 1% 3 Wire + G 10: Lutron Athena Wireless Node - RF Only 11: Casambi 12: nLyte 13: Enlighted 14: Other - Consult Factory | N : None E : External |
| 8 : Blind Cove ⁴ | 9 : Wire Length | 10 : Shape | 11 : Fixture Length |
| N : No | 12" 24" 48" 96" Custom - (Consult Factory) | S - Straight U - U Shape L - L Shape R - Rectangle P - Pattern (Consult Factory) | X' Y" |

Flat Milky : No Imaging - 50% Light Loss

| OUTPUT | SL | L | M | H | SH |
|-------------|-----|-----|-----|-----|-----|
| Lumens/Foot | 115 | 204 | 339 | 575 | 670 |
| Watts/ Foot | 1.6 | 2.8 | 4.8 | 8.3 | 9.8 |
| Lumens/Watt | 73 | 72 | 71 | 69 | 68 |



Driver Wiring



Installation Guide

Specification Details

| | LENS | LIGHT LOSS | VISIBLE DIODES | LOW | High | | |
|--------------------------------|--|------------|----------------|-------------------------------|---------|--|--|
| Watts / Foot | | N/A | | 2.2 | 4.4 | | |
| mA / Foot | | N/A | | 92 | 184 | | |
| Lumens / Watt | | N/A | | 136 | 136 | | |
| No Lens: Lumens / Foot | None | 0% | No | 288 | 576 | | |
| 0-10 / Lutron Athena Node | Max Load @ 96 Watts | | | 40 Feet | 20 Feet | | |
| DMX / DALI | Max Load @ 96 Watts | | | 40 Feet | 20 Feet | | |
| Phase | Max Load @ 96 Watts | | | 40 Feet | 20 Feet | | |
| POE | Consult Factory | | | | | | |
| Lutron Drivers | LDE1 Hi-Lume 1% EcoSystem. Soft On Fade to Black | | | L3DA3W Hi-Lume 1% 3 WIRE+G | | | |
| Color Temperatures (K) + Flux | 2700 (100%), 3000 (100%), 3500 (115%) | | | | | | |
| Max Run Length | 20 Feet | | | | | | |
| CRI | 90+ | | | | | | |
| R9 | 50+ | | | | | | |
| MacAdams Ellipses | 3 Steps | | | | | | |
| Beam Angle ² | 120 Degrees | | | | | | |
| IP Rating | IP20 - Dry Location | | | | | | |
| Lamp Life | 50,000 Hours | | | | | | |
| Dimming / Control ³ | 0-10 / POE / DMX / DALI / PHASE / LUTRON / LUTRON WIRELESS | | | | | | |
| Operating Temperature | -13°F to 122°F | | | | | | |

FINISH

Standard Mill Aluminum Finish.
Powder Coating to any RAL# available upon specification
Increased pricing for powder coating.

Warranty

2 Year Limited Warranty - Covers all Scout manufactured products.
Default to manufactures warranty for all 3rd party components. Does not cover labor.

ORDER DETAILS

- All fixtures come standard with starter end cap feed unless otherwise specified.
- All Scout Select Fixtures come preassembled up to 8 feet long with 8" power feed.
- Any Fixture length under 8 feet long will be made as a complete fixture.
- Any Fixture length over 8 feet long will be broken into 6 foot lengths + the balance length. A 10 Foot Fixture will be broken into 1 length @ 6 Feet and 1 @ 4 Feet.
- Fixtures daisy chain together with Scout_Lock™ Technology.
- In situations where fixtures are longer then the maximum wattage load new power will be injected from either the side or rear. Standard Injection is side Feed 1.
- All orders come with an approval drawing. Fabrication will not begin until drawing has been signed off or waived.

¹Lumens / Watt accounts nominal driver efficacy at full load

² Finish: Mill Finish comes standard. Cost Adder for Power Coating. Contact Factory for Custom RAL#

³ Feed: See Feed Details on page 4

LED SYSTEM

Proprietary linear LED Scout Engine incorporates premium Cree LEDs on a robust platform to achieve excellent thermal management. LEDs are placed to promote a uniform appearance.
Available in 2200K, 2700K, 3000K, 3500K, 4000K or 5000K in 90+ CRI. LED modules and drivers are replaceable.
Color accuracy <3 SDCM

CONSTRUCTION

One piece extruded aluminum housing. Cast aluminum end caps.

OPTICS

Extruded High Transmission Milky Acrylic Lens with No LED imaging. Extruded High Transmission Frosted Acrylic Lens with LED imaging.

ELECTRICAL

Fixture comes reassembled with 8" whip.
All Drivers are installed in remote location.
All drivers are Universal input 120-277 VAC.
Standard Constant Voltage drivers include 0-10V dimming preinstalled in enclosure.

LABELS

Conforms To UL STD 2108 Certified To CSA STD C22.2 # 250.0
Suitable for Dry or Damp Locations, indoor use only.
ETL Control # 5011600